

Wind 'N Go® Camp Lantern #7858

IMPORTANT SAFEGUARDS

- Read all instructions before operating
- Do not operate at temperatures above 120°F or below 32°F
- To reduce the risk of electric shock, do not submerge the unit or its accessories in any liquid. Unit is water resistant but not waterproof.
- Do not use in flammable or explosive environments
- For better light quality, protect the lantern globe from scratching
- Turn off lantern before charging
- For maximum battery efficiency, never completely deplete stored power
- Store in a clean dry place when not in use
- Administer close supervision when using around children

PARTS IDENTIFICATION

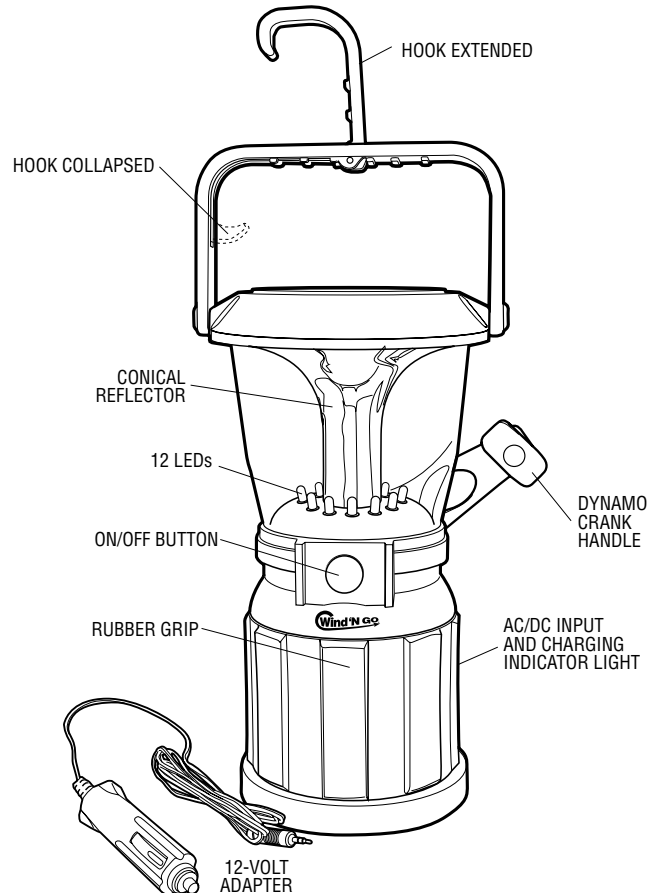

CHARGING

For all methods of charging, make sure the lantern is off or the battery will not charge completely. If the unit has not been used for more than 30 days it is recommended that you recharge using the included DC charger, or the available AC/DC Power Adapter (#7990 sold separately) to recondition the rechargeable battery.

During any of the following methods of charging the red charging indicator light will illuminate. Leaving either auxiliary charging adapter connected after a full charge is achieved will not harm the lantern.

Dynamo Charging:

1. Open the Dynamo Hand Crank and rotate steadily clockwise at approximately 130 cycles/minute for a minimum of 1 minute. Longer wind-up times will yield a longer power duration.
2. Close the arm.

12-Volt DC Charging Adapter (included):

1. Plug the charger into the input jack of the lantern and into your vehicle's cigarette lighter or accessory outlet.
2. Allow 3 hours to achieve a full charge.

AC Charger (#7990 available but not included):

1. Plug the charger into the input jack of the lantern and into an AC wall plug.
2. Allow 3 hours to achieve a full charge.

OPERATION

Press the ON/OFF button

- once to illuminate 6 LEDs
- twice to illuminate 12 LEDs
- three times to turn everything off

To hang the lantern, extend the hook from the handle to an upright position (see drawing)

ACCESSORIES

#7990 AC/DC Power Adapter

TECHNICAL INFORMATION

SPECIFICATIONS	
INTERNAL RECHARGEABLE BATTERY	3.6V 600mAh NiMH
WEIGHT	1 lb. 12 oz.
DIMENSIONS	4.4" W x 9.6" H
DC CHARGER (INCLUDED)	Input: 12V DC Output: 6V 300 maH Fuse: F2AL250V glass fuse
AC/DC CHARGER (NOT INCLUDED)	Input: 120V AC 50/60 Hz Output: 6V 300 maH Positive polarity

POWER DURATION	LANTERN
After winding for 1-3 minutes at 130 rpm	30 minutes 6-LEDs 20 minutes 12-LEDs
Charging with the 12V DC or 120V AC/DC adapter for 3 hours	6 hours 6-LEDs 3 hours 12-LEDs



ATHENA BRANDS

An Aervoe Industries, Inc. Company

Gardnerville, NV 89410 • 1-800-272-8603

www.athenabrands.com • mailbox@athenabrands.com

Wind 'N Go® is a registered trademark of Aervoe Industries, Inc.

7858inst; cs4/08

Wind 'N Go®

Camp Lantern

Patent Pending

OPERATING INSTRUCTIONS

